

ME 511 Mechatronics @ UIC

Bipolar Junction Transistor as a switch and an amplifier. Photoelectric Circuit.

This lab is to be done in a group of two during lab hours

1 Prelab (To be done before you come to the lab)

1.1 Motivation

The goals of the lab are to introduce you to a bipolar junction transistor and its use as a switch and as an amplifier. We will also understand another transistor called a photo-interrupter.

1.2 Assigned Reading

This part of the Lab needs to be done before you come to the lab. Assigned reading from the textbook is listed below

1. 3.4 Bipolar Junction Transistor including 3.4.1 Bipolar Transistor Physics, 3.4.2 Common Emitter Transistor Circuit, 3.4.3 Bipolar Transistor Switch, 3.4.4 Bipolar Transistor Packages, 3.4.6 Phototransistor and Optoisolator. This is also covered in Lecture 8 and 9.
2. Class Discussion Item 3.2 (page 90) Inductive kick. Use google search to read about flywheel diodes.

1.3 Questions based on reading (not graded)

1. Which of the following are TRUE for a npn transistor
 - (a) The base is denoted by p.
 - (b) The collector is denoted by n.
 - (c) The emitter is denoted by n.
 - (d) The emitter is more heavily doped than the collector.

2. Which of the following are TRUE for a npn transistor in common emitter transistor circuit.
- (a) Base Emitter is forward biased
 - (b) Base Emitter is reverse biased
 - (c) Base Collector is forward biased
 - (d) Base Collector is reverse biased
3. Which of the following are TRUE when the npn transistor is saturated.
- (a) $V_{CE} = 0.2 V$
 - (b) $V_{BE} = 0.7 V$
 - (c) $I_E = I_C + I_B$
 - (d) $I_C > 0$ and $I_B > 0$.
4. A BJT transistor has three modes: Cutoff, active and saturation. For BJT to act as a switch we cycle between which modes.
- (a) Cutoff and Active.
 - (b) Cutoff and Saturation.
 - (c) Active and Saturation.
 - (d) Cutoff, Active and Saturation.
5. In which of the following circuits needs a flyback diode.
- (a) Circuit with a resistor and a capacitor.
 - (b) Circuit with a resistor, an inductor, and a switch.
 - (c) Circuit with a resistor only.
 - (d) Circuit with a motor and a transistor.

Answers: 1 a, b, c, d; 2 a, d; 3 a, b, c, d; 4 b; 5 b, d;

2 Labwork (graded)

Equipment list

1. 1 npn Bipolar Junction Transistor
2. 2 resistors of value $1k\Omega$ and 1 resistor of value 330Ω and $10k\Omega$.
3. 1 DC motor
4. 1 TIP31C power diode
5. 1 Photo-interrupter
6. 1 Diode
7. 1 DC motor.
8. Breadboard.
9. Hantek2D72 Oscilloscope/Digital Multimeter/Function Generator (please return this back at the end of the lab).
10. DC voltage supply (please return this back after the lab is done).

2.1 (10 pts) Identification of a Bipolar Junction Transistor

Search the spec sheet of the npn Bipolar Junction Transistor given to you. Draw the BJT in the space given below and indicate the base, emitter, and collector. Show the drawing to the teaching assistant.

2.2 (30 pts) Bipolar Junction Transistor as a switch

You will build the circuit shown below. Use the 2N2222 small signal transistor. Use the function generator to control V_{in} (constant value). Use the DC power supply for the 10V source. We will use different value for R_B as indicated next.

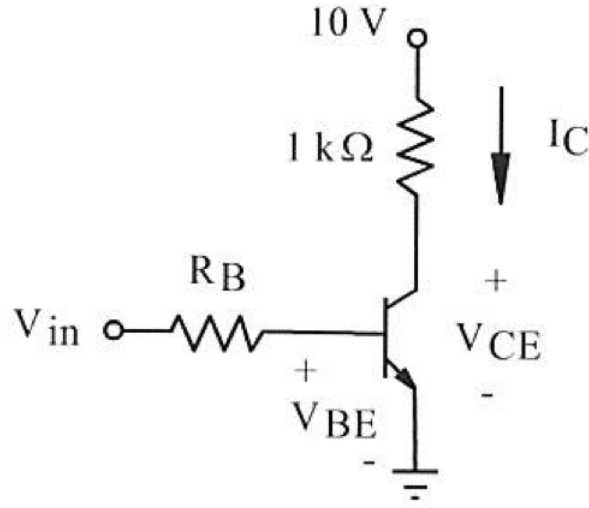

1. Use $R_B = 1\text{ k}\Omega$ for this experiment. Vary V_{in} and record the values of V_{BE} and V_{CE} in the table below.

V_{in}	V_{BE}	V_{CE}
0		
0.4		
0.5		
0.6		
0.7		
0.8		
0.9		
1.0		

2. Use $R_B = 100\text{ k}\Omega$ for this experiment. Vary V_{in} and record the values of V_{BE} and V_{CE} in the table below.

V_{in}	V_{BE}	V_{CE}
0		
0.4		
0.5		
0.7		
0.9		
1.1		
1.3		
1.5		

Discuss these questions among your group members.

1. When does the BJT saturate for both cases?
2. What is the effect of increasing the base resistor?

Now show your circuit and discuss your answers with the teaching assistant.

2.3 (30 pts) Bipolar Junction Transistor as an amplifier

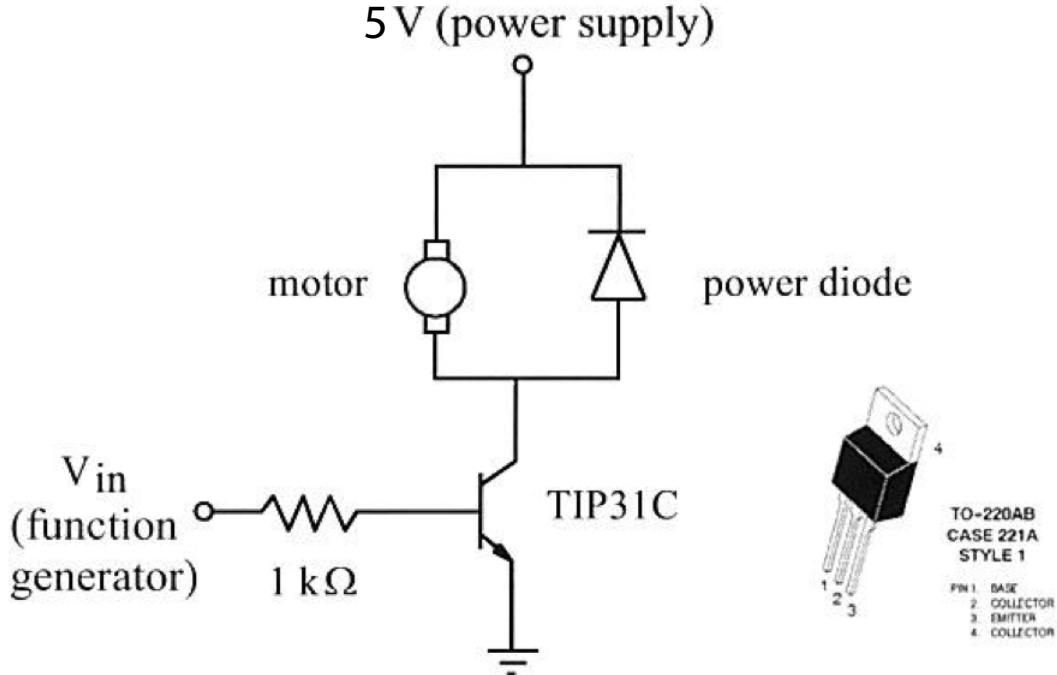

Build the circuit shown above. Use the power transistor provided to you (check the specs sheet for the pinout of the transistor, do not rely on the pin out shown in the figure) and the DC motor given to you. We **cannot** use the 2N2222 transistor because it cannot handle the large motor current needed to drive the motor. There is a diode in series with the motor. The diode in this configuration is called a flywheel diode. It is recommended to use flywheel diode to prevent sparks that might occur in inductive load (e.g., motors and solenoids) when the supply voltage is suddenly shut-off.

1. Gradually increase V_{in} from 0 to 6 V in small increments till the motor starts spinning. Find the critical voltage at which the motor starts spinning. Call this voltage V_{inc} . Now do the reverse, that is, gradually decrease V_{in} from 6 V to 0 in small decrements till the motor stops spinning. Find the critical voltage at which the motor stops spinning. Call this voltage V_{dec} . Is $V_{inc} = V_{dec}$? Why not? Also, discuss what does it mean for a BJT to act as an amplifier. Now demonstrate the circuit to the teaching assistant and explain the motor behavior.
2. Apply a square wave V_{in} with the following features: (i) A DC offset of 3, (ii) An amplitude of 2.5. Increase the frequency of the square wave from 0 to 20 Hz in increments of 2 Hz and then from 20 Hz to 100 Hz. Observe the motor. Discuss among group members. Now demonstrate the circuit to the teaching assistant and explain the motor behavior.

